

ENEVA ESG SERIES HIGH EFFICIENT STEAM GENERATORS

ENEVA ESG steam generator design is based on well proven radiant and tubular heat transfer mechanisms which provides economical and reliable steam production to many of industrial plants.

Unlike water tube (coil) steam generators, our Smoke tube steam generators are highly tolerant to many kind of feed water conditions. Thanks to large water and steam volume inside, dry steam is produced without any external steam accumulator application.

In case of any tube failure, operator may repair the generator just opening the doors, in case of coil type generators in many cases, all of the coil have to be replaced with new one.

Our steam generators are designed considering all of the critical parameters carefully such as fuel specification, steam capacity, internal water and steam volume, water evaporation surface area, thermal expansions, flue gas side pressure drop and optimized heat transfer surfaces.

Thanks to large water volume and evaporation surface, plant steam load fluctuations are easily met.

Our steam generators are completely welded construction and shop assembled, including all of the manufacturing processes such as cutting, bending, welding and other operations.

All steam generators are designed according to European shell boiler norm (EN 12953) or American norms (ASME) if required by the customer.

After maintaining a good combustion in quite large combustion chamber, flue gases go along second smoke tube passes to ensure enough heat transfer for maximum thermal efficiency.

Combustion chambers (furnaces) are designed considering flame dimensions and volumetric combustion load (heat flux to furnace) not to let form high NO_x emission in the stack flue gases.

Based on the pressure and capacity of the generator, combustion chambers could be corrugated type (fox or morrison) to compensate thermal expansions and to maintain stronger structure to external pressure.

After assembly and welding operations, steam generators are hydrotested at required pressures with water and painted with high temperature resistant paint.

External insulation consists of min. 100 mm rock wool + aluminium, stainless steel or galvanized steel depending on the conditions and customer request if any.



MAIN SPECIFICATIONS

- Design and manufacturing up to 4 tph capacity depending on pressure
- Liquid, gas and biogas / hydrogen fuel options
- High efficiency with low thermal losses from stack and external surfaces
- Perfect design for optimal heat transfer and flue gas pressure drop
- Low NO_x formation with well designed large combustion chamber
- Large steam volume and evaporation surface for dry steam supply
- Easy reachable combustion chamber and smoke tubes for maintenance
- Design acc. to EN 12953 and CE certification acc. to 2014/68 EU PED
- Thermal efficiency up to %100 with additional economizers

DELIVERY OPTIONS

- ✓ Armature, pump unit, burner and all instruments in accordance with EN 12953
- ✓ 72 Hour / 24 Hour operation without guard
- ✓ Feed water economizer, condensing economizer or air preheater (recuperator) up to request
- ✓ Deaerator package or integrated condensate tank
- ✓ Automatical blowdown systems

ENEVA ESG SERIES HIGH EFFICIENT STEAM GENERATORS

MATERIAL SPECIFICATIONS

Body Shell, dome and tube plates :

EN 10028 / 2 - P265 GH, P295 GH, P355 GH Boiler steel

Furnace :

EN 10028 / 2 - P265 GH, P295 GH, P355 GH Boiler steel

Smoke tubes :

EN 10216 / 2 - P235 GH, - TC1 Seamless boiler tube

Thermal insulation :

100 mm rockwool covered with aluminium or galvanized plate

Refractory application :

Ceramic fiber + Alumina based high resistant castable concrete

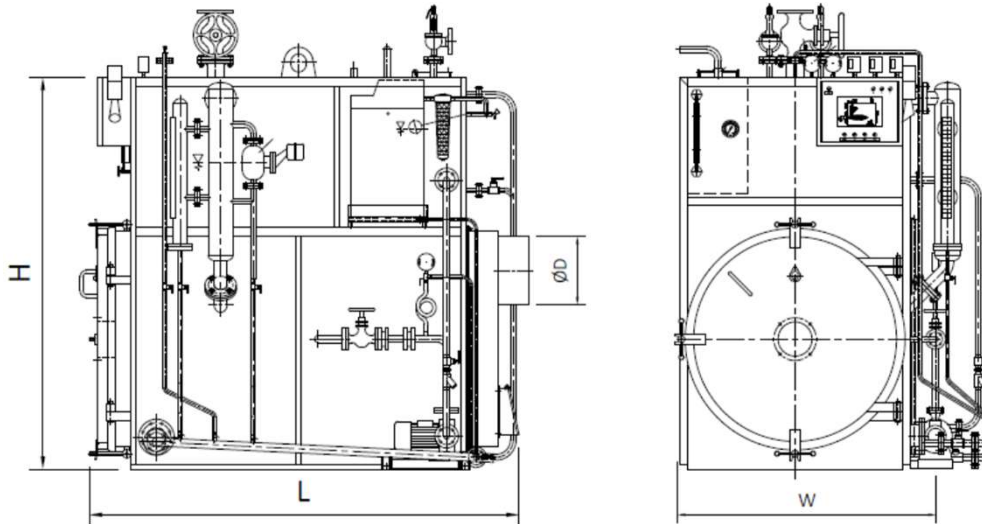
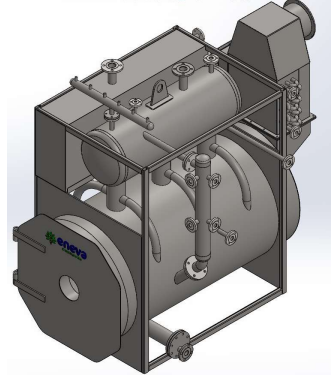

ESG SERIES STEAM GENERATOR PRELIMINARY DIMENSIONS

ESG SERIES STEAM GENERATOR TYPICAL DIMENSIONS

Model		ESG-0.3	ESG-0.5	ESG-0.6	ESG-0.8	ESG-1.0	ESG-1.25	ESG-1.5	ESG-2.0	ESG-3.0	ESG-4.0
Steam Output	t/h	0,3	0,5	0,6	0,8	1,0	1,3	1,5	2,0	3,0	4,0
Thermal Output	kW _t	204	340	408	544	680	850	1020	1360	2.041	2.721
Fuel Consumption	kW _t	235	391	469	626	782	977	1.173	1.564	2.346	3.128
Flue Gas Back Pressure	mbar	3,0	4,0	4,0	5,0	5,0	6,0	6,0	7,0	8,0	9,0
Water Volume, Nominal	m ³	0,4	0,5	0,6	1,0	1,3	1,6	2,0	2,6	3,9	5,2
Overall Length, L	m	1,8	2,0	2,1	2,4	2,7	2,9	3,1	3,3	3,5	4,0
Overall Width, W	m	1,3	1,4	1,5	1,6	1,7	1,8	1,9	2,1	2,3	2,4
Overall Height, H	m	1,8	1,9	2,0	2,3	2,5	2,7	2,8	3,0	3,2	3,4
Steam Outlet Flange, PN16	DN	40	50	50	65	65	65	80	80	100	125
Safety Valve Flange, PN16	DN	25	25	25	25	25	25	25	32	32	32
Flue Gas Outlet Diameter, d	mm	273	273	273	323	323	350	350	400	450	500
Shipping Weight	t	1,1	1,4	1,6	2,0	2,9	3,5	4,1	5,3	6,8	8,6

Note : Values are valid for 6 barg operation pressure, min. 80 °C feed water temperature, natural gas fuel and operation with out economizer.
All data is subject to technological developments. For different pressure and steam capacities consult us.

ENEVA ENERJİ SİSTEMLERİ MÜHENDİSLİK SANAYİ VE TİCARET LİMİTED ŞİRKETİ

A: Yakuplu Mah., Hurriyet Blv., Skyport Sit. No: 1/64, PK: 34520 Beylikduzu / İSTANBUL / TÜRKİYE

T: +90 (212) 982 46 14, E: info@enevaenerji.com.tr, W: www.enevaenerji.com.tr